

CAS AT7



Conveyor
Application
Systems



All-Terrain Mobility

Remote Access

The AT7 is controlled entirely with remote control for all systems in addition to the dual speed tracking and maneuvering of the unit in limited access job sites. It allows the operator to work from any vantage point for better safety and accuracy.

Adjustable Leveling

The All-Terrain has an automatic/remote controlled tiling feature for leveling the equipment of adverse terrain. The self-leveling feature provides stability during operation and continuous feeding on sloped areas of application.

On-Site Loading

With hopper extensions in place, the unit can be easily loaded from the side or the rear with your own loading equipment. The All-Terrain is designed to blend with your existing operation or to establish a viable profit center.

Extreme Accessibility

The All-Terrain comes with standard with Off-Road Traction Floatation Tires for all-terrain mobility. Accessibility is the key for this particular unit to keep it working on the toughest of job sites. An optional High Floatation configuration may be used for beach restoration work or turf applications such as in golf course and sports field construction.

CASAT7

Details and Specifications

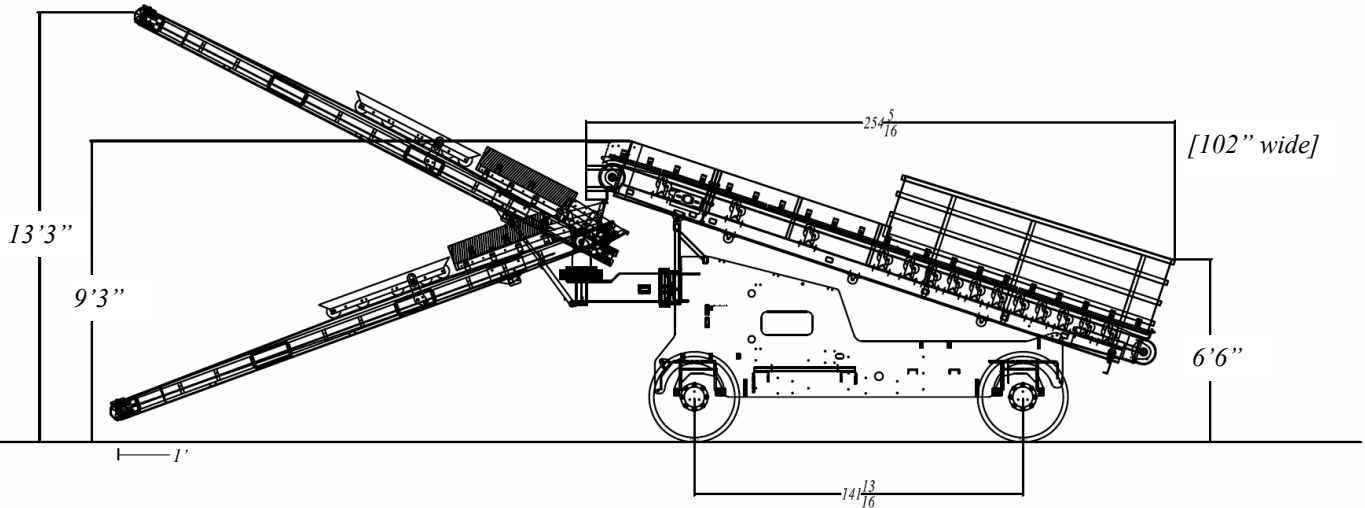

Chassis and Frame

- Quality Steel Construction
- Hydraulic 12° L & R Leveling System
- Optional Dozer Blade
- Powder Coat Finish

Engine and Drive Train

- Caterpillar C6.6 202HP Tier 3 Engine
- 20,000 lb. Crab Steering Front Axle
- 20,000 lb. Crab Steering Rear Axle
- 15" x 19.5" Floatation Tires
- 2 Speed Direct Hydraulic Drive

Feed Conveyor

- Modular Unibody Type
- Hydraulic Drive
- Sealed Bearing Troughing Rolls
- 24" Wide 220 2-Ply Belt
- Lagged Head Pulley: 10"W x 26"L
- Tail Pulley: 10"W x 32"L

Placing Conveyor

- CAS exclusive 14" Long Shot Belt with 1/2" Cleats
- Tube Steel Design
- High Performance Rear Mounted Direct Drive
- Poly Filled Bearings
- Worm Gear Pivot

Hydraulic System

- Dual Load Sensing Hydraulic Piston Pumps
- Sauer Danfoss Piston Hydraulic Motors
- Dual Pressure & Return Filtration (10 Micron Absolute Rating)
- Hawe Proportional Valves
- High Pressure Hoses & Fittings

Electrical System

- Omnex Radio and Receiver Control Package with Frequency Hopping
- Wireless Travel and Placing Control Functions

Standard Equipment

- Cleated Placing Conveyor Belt
- Power Super Shield
- Work Lights
- Tool Box
- Pressure Washer System with 30 Gallon Tank & Reel

Optional Equipment

- Concrete Placing Equipment
- 1/2 yd³ Dump or Transfer Hopper with Control Wings
- 25' Placing Conveyor (with stands) with Smooth Belt for Concrete
- Retracting Super Shield, Elephant Trunk & Scraper

Weight

- Approximately 18,000 lbs.

7 Cubic Yard Capacity Steel Hopper

- High Tensile Steel with 10 Gauge Sheeting
- Powder Coated Interior & Exterior
- UHMW Lines

Conveyor Application Systems, LLC

1275 Bailey Hill Road
Eugene, OR 97402

1-888-279-4227

www.slingers.com



**Conveyor
Application
Systems**